

# FEIDER

## MACHINES



## ELECTRIC LOG SPLITTER

### FFBE7TS

### USER GUIDE

CAUTION: Read this manual before using this machine!

# CONTENTS

1. DESCRIPTION OF SYMBOLS.....	3
2. SAFETY INSTRUCTIONS.....	5
3. TECHNICAL SPECIFICATIONS.....	7
4. ASSEMBLY.....	7
5. OPERATION.....	12
6. MAINTENANCE.....	15
7. STORAGE.....	15
8. TROUBLE SHOOTING.....	16
9. DISPOSAL.....	16
10. DECLARATION OF CONFORMITY.....	17
11. WARRANTY.....	18
12. PRODUCT FAILURE.....	19
13. WARRANTY EXCLUSIONS.....	20

# 1. DESCRIPTION OF SYMBOLS

**WARNING!** Standard graphic symbols are used on all machines in order to ensure complete safety of all parts of the log splitter. As these symbols are very important, read the information below attentively.



Conforms to relevant safety standards.



It is obligatory to read the machine's use and maintenance manual in full before using the machine.



Check your log splitter before turning it on. Keep guards in place and in working order.



It is obligatory to wear safety footwear at all times to provide protection against the risk of logs accidentally falling on feet.



The requirement of eye protection, head protection and ear protection when using the product.



It is obligatory to at all time to wear gloves which protect the hands against chips and splinters which may be produced during work.



Warning: always pay attention to the movement of the log pusher.



Keep hands out of the way of all moving parts.

“Danger! Keep clear of moving parts!”



The log splitter must be always operated by one person only.

Other people should keep a safe distance from the work area, especially when the log splitter is under operations.

Never use another people to help you with freeing jammed log.



Warning: pay attention to prevent entrapment hazard.



Take used oil to an authorized collection point or follow the stipulations in the country where the log splitter is used. Do not discharge into drains, soil or water.



Keep your hands away from splits and cracks which open in the log; they may close suddenly and crush or amputate your hands. Do not remove jammed logs with your hands.



WARNING! Electricity - Risk of electric shock.



Remove plug from mains before maintenance or if cord is damaged



Do not remove jammed trunks with your hands.



Keep your work space tidy! Untidiness can lead to accidents.



No smoking in the working area.



Take used oil to an authorized collection point or follow the stipulations in the country where the log splitter is used. Do not discharge into drains, soil or water.

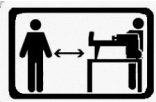

The log splitter must be always operated by one person only. Other people should keep a safe distance from the work area, especially when the log splitter is under operations. Never use another people to help you with freeing jammed log.



Recycle unwanted materials instead of disposing of them as waste. All tools, hoses and packaging should be sorted, taken to the local recycling center and disposed of in an environmentally safe way.

**Danger! Keep clear of moving parts!**

**To be operated by one person only!**

**The log splitter must be used horizontally, can't be used vertically.**

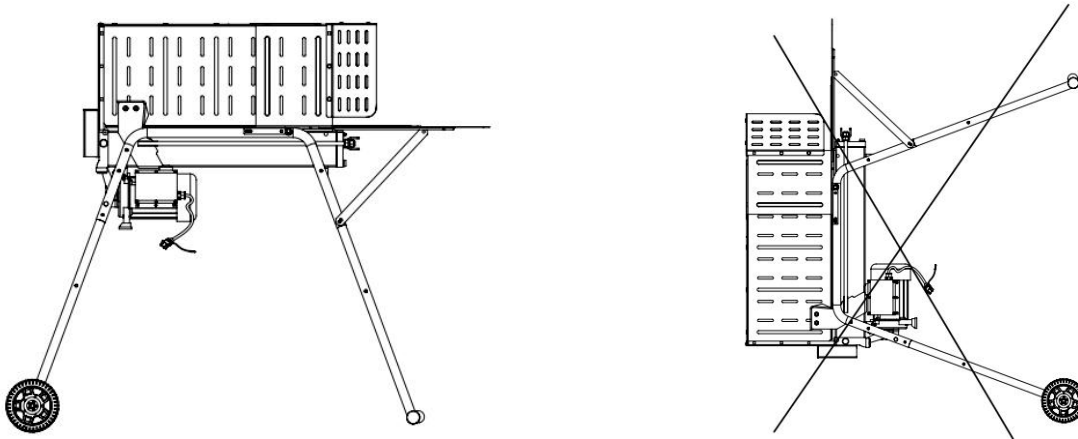

## 2. SAFETY INSTRUCTIONS

**Keep these instructions for future reference**

1. The log splitter must always be used by one operator only.
2. Nobody must be allowed to use the log splitter unless they have read the instruction manual and have been instructed in the regulations to follow for correct and safe use.  
Operators must receive necessary training and instructions.
3. The machine must be used by adults only. Use of the log splitter by apprentices of not less than 16 years of age must be supervised by an adult authorized to use the machine.
4. Never wear loose, unbuttoned clothing which may become trapped in moving parts.
5. Check that the logs to be split are free from nails or wire, which may fly up or damage the machine, the ends of the logs must be cut square, branches must be cut off flush with the trunk.
6. Never try to split logs larger than those indicated in the technical specifications. This could be dangerous and may damage the machine.
7. Break wood in the direction of the grain, do not place wood across the log splitter and leave it in that position for splitting; it may be dangerous and may seriously damage the machine.
8. Never attempt to cut two logs at once, one may fly up and hit you.
9. If the log moves away from the blade, retract the blade and turn the log through 90°.
10. Do not attempt to load the log in the log splitter while the blade is in motion, you could get trapped and injured.
11. Keep your hands well away from any splits and cracks which open in the log; these may close suddenly and crush or amputate your fingers.
12. Never force the log splitter for more than 5 seconds keeping the cylinder under pressure in the attempt to split excessively hard wood. After this time interval, the oil under pressure is overheated and the machine could be damaged. It is thus better to stop and rotate the log by 90° to see whether it can be split in a different position. In any case, if you are not able to split the log, this means that its hardness exceeds the capacity of the machine and thus that log should be discarded so as not to damage the log splitter.
13. Do not force the blade by pushing the log on the upper part, as this can cause the blade to break or damage the body of the machine. Always set the log on the guides.
14. Never leave the machine unattended while it is running. If you leave the machine, even for a short time, remove the power supply or any possible cause of accidental start-up.
15. The log splitter must never be used by an operator who is under the influence of alcohol, drugs, medicines, or who is tired. A clear mind is essential for safety.
16. Never request the assistance of another person to help you remove a jammed log.

17. Do not use machines with electric motor if natural gas, petrol fumes or other inflammable vapors are present.
18. Check that the electric circuit is adequately protected and that it corresponds with the power, voltage and frequency of the motor, check that there is a ground connection, and a regulation differential switch upstream.
19. Check on the functioning of the machine.
20. Never open the switch box on the motor. Should this be necessary, contact a qualified electrician.
21. Make sure that the machine and the cable never come in contact with water.
22. Treat the power cable with care, do not attempt to move the machine by pulling the cable, do not yank the cable to unplug it; keep the cable away from excessive heat, oil and sharp objects.
23. Never leave the machine unattended with the power supply "on", also disconnect the power cable when not in use, when carrying out maintenance work, when changing attachment or moving the machine.
24. Before starting work, hydraulic pipes and hoses shall be inspected and the stopping devices shall be tested.
25. Stop the machine before cleaning or making adjustments.
26. The hazards may arise from particular characteristics of wood when being split (e.g. knots, logs of irregular shape etc.).
27. Operator must receive necessary training and instruction from a qualified person before handling the tool.
28. Use the tool only for the intended use. Misuse (such using material other than log) can damage the tool and cause accidents and injuries.
29. The splitting operation of the machine is designed to be activated by one person. While there is the possibility that additional operators could be working with the machine (e.g. for loading and unloading), only one operator should activate splitting operations;
30. The machine shall not be used by children
31. Wear suitable personal protective equipment (PPE), including safety footwear close fitting clothing and suitable work gloves, eye protection and hearing protection.
32. Tests of the machine's safety devices before use the tool. If safety devices do not work properly, do not use the tool and bring it to a qualified technician for inspection and reparation.
33. The working area shall be free from obstructions; before installation and operation, clear the working area. Keep the working area free from obstructions, e.g. logs, split wood, etc.
34. Do not reach into the splitting zone.

## **TRANSPORTING THE WOODEN SPLITTER TO THE PLACE OF WORK**

The log splitter is equipped with 2 wheels for minor displacements. To move the log splitter to your workplace, roll log splitter at a slight angle after making sure the oil tank cap is tight.

Do not lift or carry the log splitter to move it.

### **Electrical Safety**

**WARNING!** Always check that the power supply corresponds to the voltage on the rating plate.

**WARNING! Connect the main leads to a standard 230V±10% (50Hz±1Hz) electrical supply which has protection devices of under-voltage, over-voltage, over-current as well as a residual current device (RCD) which maximum residual current rated at 30mA.**

### **Replacing cables or plugs**

If the supply cord is damaged, it must be replaced by the manufacturer, its service agent or similarly qualified persons in order to avoid a hazard.

Immediately throw away old cables or plugs when they have been replaced by new ones. It is dangerous to insert the plug of a loose cable in the wall outlet.

## Using extension cables

1. As a supply for this machine always use an unloaded line and/or extension with conductor of at least 2.5mm<sup>2</sup> and protected with a 20A fuse. Be sure that this extension cable is no longer than 10 meters. Excessively long cables or inadequate section can cause voltage drops that prevent motor from developing its full power.
2. Only connect your machine and/or extension cable to earthed electricity mains.

## Grounding

In the event of an electrical short circuit, grounding reduces the risk of electric shock. Use switch socket with grounding please.

## INTENDED USE

This log splitter is only intended to be used to split logs! Serious injury may occur if this log splitter is used for any other purpose.

# 3. TECHNICAL SPECIFICATIONS

<b>Model</b>	FFBE7TS
Voltage:	230V~ 50Hz
Power consumption	2300W S3 50% (5min on/5min off)
No load Speed:	2800/min
Classification	Class I
Protection degree	IP54
Max. splitting force (tons)	7T
Diameter	30-250mm
Max. Cutting Length	520mm
Max. Hydraulic oil capacity	2.4L
Max. hydraulic pressure	28MPa
Mass	67kg
Sound pressure level, L <sub>pA</sub>	78 dB(A) k=3dB(A)
Sound power level, L <sub>WA</sub>	91 dB(A) k=3dB(A)
Vibration	≤2,5m/s <sup>2</sup>

# 4. ASSEMBLY

## UNPACKING

**WARNING!** To prevent accidental starting that could cause possible serious personal injury, assemble all parts to your log splitter before connecting it to power supply. Log splitter should never be connected to power supply when you are assembling parts, making adjustment.

Carefully remove all pieces from the carton. Place the log splitter on a flat, high work surface so that the control actuators are at least 850 mm (maximum: 1650 mm) high from the ground.

Separate and check against the list of loose parts.

**WARNING!** If any parts are missing, do not operate this machine until the missing parts are replaced. Failure to do so could result in serious personal injury.

- Do not discard the packing materials until you have carefully inspected the log splitter, identified all parts, and satisfactorily operated your new log splitter.

Check all loose parts from the box with the list below. Assemble according to the instruction on the following pages.

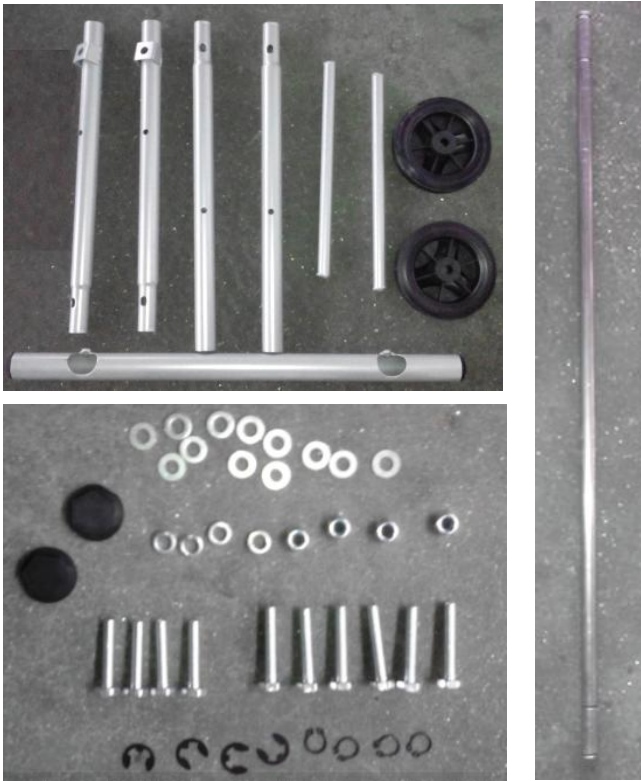

- |                     |       |
|---------------------|-------|
| 1. Horizontal leg   | 1pc   |
| 2. Front stand      | 2pcs  |
| 3. Back stand       | 2pcs  |
| 4. Horizontal shaft | 2pcs  |
| 5. Wheel            | 2pcs  |
| 6. Wheel shaft      | 2pcs  |
| 7. Wheel cover      | 2pcs  |
| 8. Circlip          | 8pcs  |
| 9. Bolt M8*45       | 4pcs  |
| Bolt M8*50          | 6pcs  |
| 10. Nut M8          | 4pcs  |
| 11. Flat washer     | 12pcs |
| 12. Spring washer   | 4pcs  |

## FEATURES

1. Before attempting to use, familiarize yourself with all the operating features and safety requirements of your log splitter.

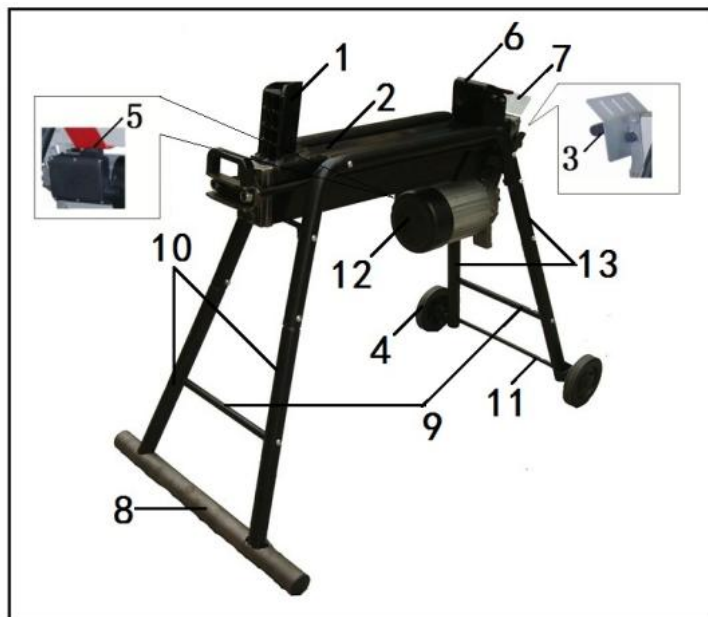

1. Blade
2. Oil tank
3. Hydraulic control lever
4. Rolling wheel
5. Push button switch
6. Log pusher
7. Safety guard for hydraulic control lever
8. Horizontal leg
9. Horizontal shaft
10. Front stand
11. Wheel shaft
12. Motor cover
13. Back stand

## 2. Size of the logs to be split

The figure 1 shows the maximum log sizes that can be split.

The diameter of the log is indicative: a small log can be difficult to split if it has knots or a particularly tough fiber. On the other hand, if the wood has regular fibers it is not difficult to split logs with diameter greater than the maximum shown in fig. 1.

**It is important not to insist when the log does not split on the first attempt, as the pump may be damaged by the overheating of the oil when the machine is made to work under the maximum stress in the attempt to split excessively hard wood.**



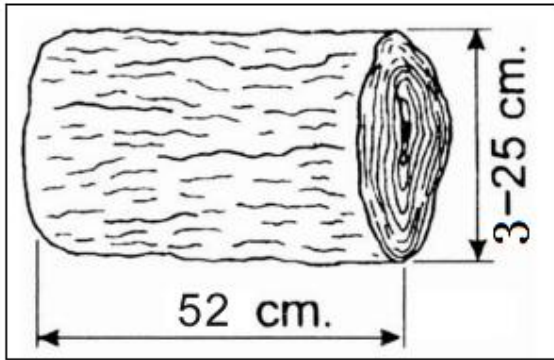

Fig.1

### 3. Recommended oils

We recommend use of the following oils for the hydraulic cylinder.

SHELL TELLUS T22

ARAL VITAM GF22

SP ENERGOL HCP22

MOBILE DTE 11 OR equivalent

**DO NOT USE OTHER GRADE OILS**

### 4. Application conditions

This log splitter is a home use model. It is designed for operating under ambient temperature between +5°C and 40°C and use at altitudes no more than 1000mm. The surrounding humidity should less than 50% at 40°C. It can be stored or transported under ambient temperatures between -25°C and 55°C.

### INSTALLATION OF PARTS

**Warning! For your own safety, do not connect the log splitter to the power source until the machine is completely assembled and you read and understand the entire instruction manual.**

**Warning! For your own safety, never forget to bolt the support legs to the log splitter, place the log splitter on flat and level ground.**

**Warning! Never use the log splitter if it is not in perfect order or if it needs servicing. Before starting work, check correct functioning of all the safety devices (ZHB, push button).**

a) Connect front stand (10a) to connection pipe (a) and front stand (10b) to connection pipe (b) by bolts and nuts (fig.2).

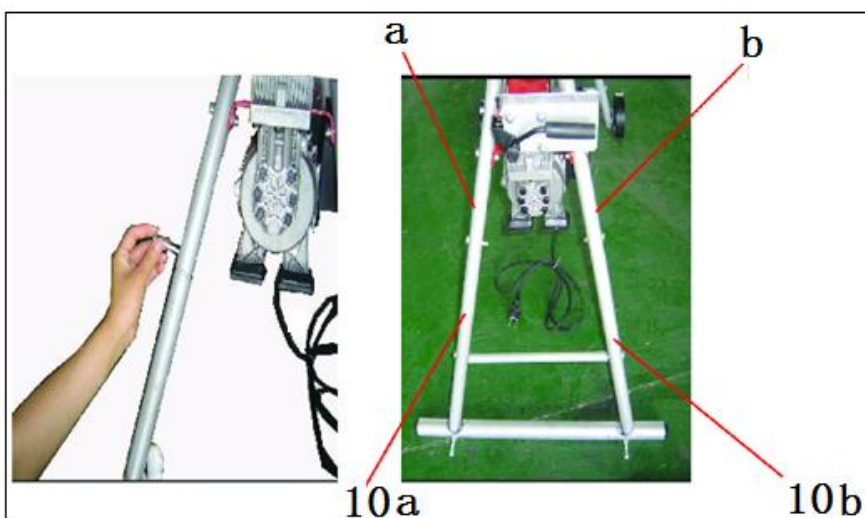

fig.2

b) Connect horizontal shaft (9a) to front stand(10a&10b) with screws, then assemble horizontal leg(8) and fix it to front stand(10a&10b) by bolts (fig.3).

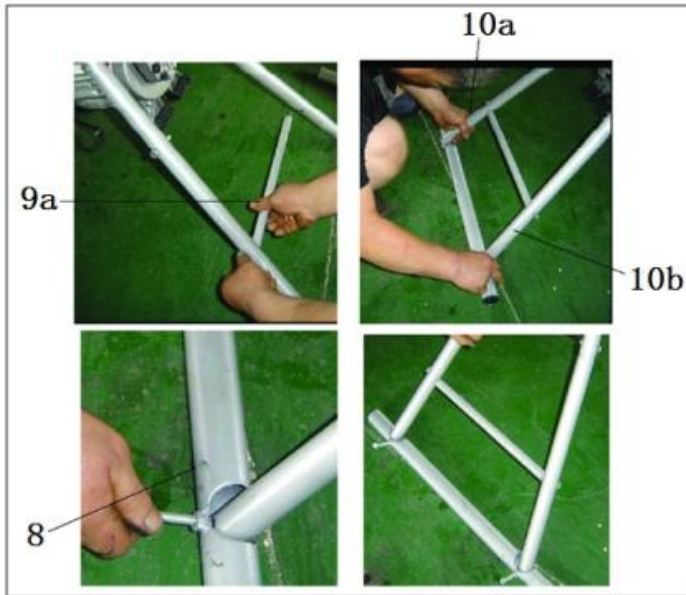

fig.3

c) Connect back stand (13c) to connection pipe (c) and connect back stand (13d) to connection pipe (d) by bolts and nuts (fig.4).

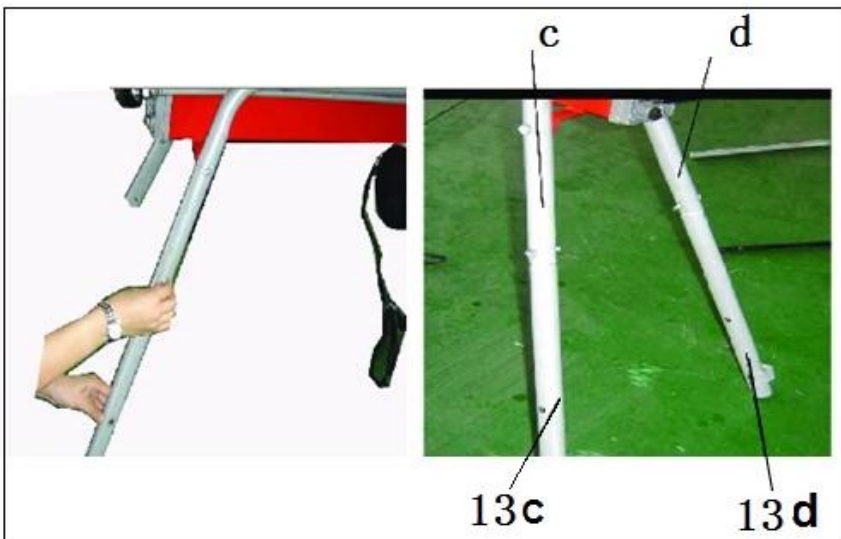

fig.4

d) Connect horizontal shaft (9b) to back stand (13c&13d) with bolts, assemble the wheel shaft (11) and wheels with four spring washers, the last fit wheel covers (fig.5).

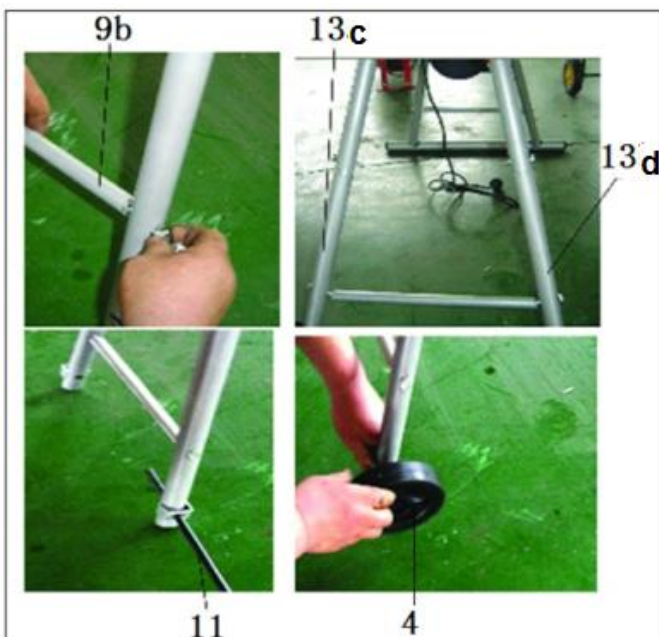
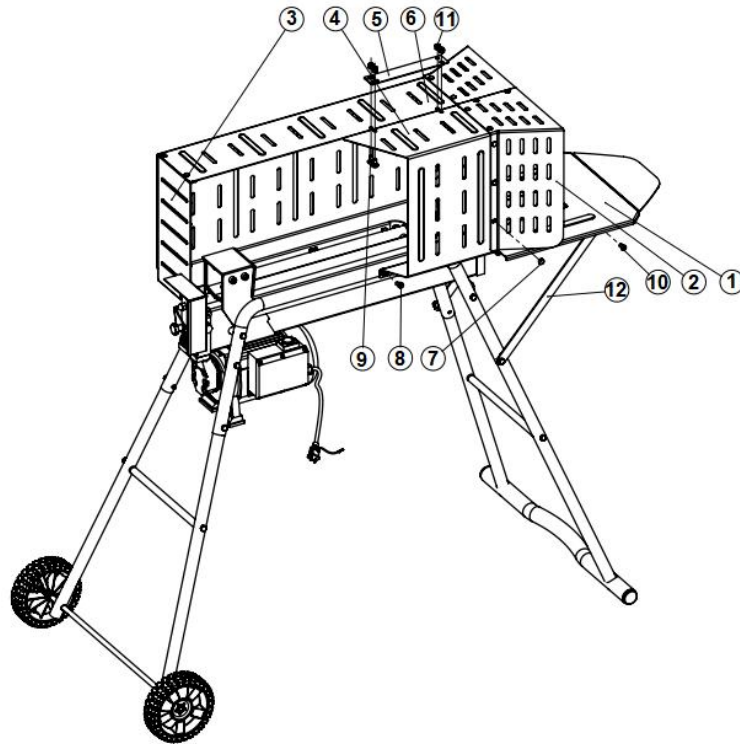

fig.5

## INSTALLATION OF THE MACHINE

①stock support plate ②protection guard 1pcs ③back cover ④left cover ⑤connection plate ⑥right cover ⑦ fixed ⑧ Inner hexagon bolt M8 ⑨ Square neck bolt M8 ⑩ Inner hexagon bolt M8



1) Install the support plate (1) on the machine by hooking the hooks under the supports provided for this purpose.

2) Install the work plates on both sides of the machine, align the holes, put the seals and screws to secure the parts.

3) Install the left cover (6) on the machine (it must be aligned with the holes in the worktable), and secure with the M8 hex bolts and M8 seals.

4) Install the cover and secure with M8 hex bolts and M8 seals.

5) Install the M8 square-head bolts (9) through the left and right cover installation holes and the connection plate and tighten the four M8 nuts.

6) Install the protective covers on the front of the unit and the rear cover on the back of the machine.

Carefully push the fasteners (7) into the installation holes of the protective covers and the rear cover, then carefully insert the fasteners into the mounting holes in the right and left covers.

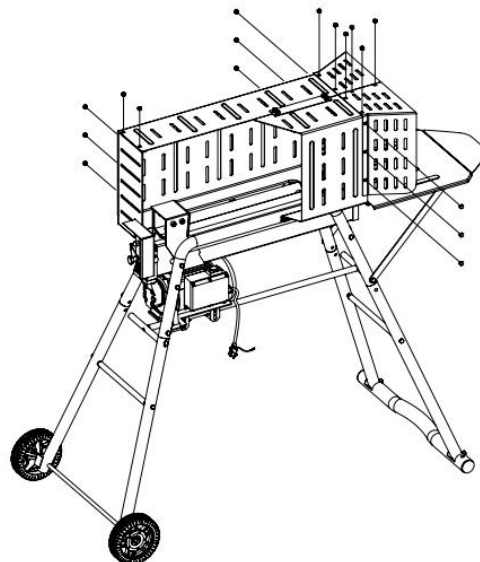

**NOTE:** If you choose a machine without extra legs, please place the machine safely on the workbench surface 850mm above the ground before using.

## 5. OPERATION

### Warning!

Before operating the log splitter, the Bleed Screw (15) Fig. 6, should be loosened by some rotations until air can go in and out of the oil tank smoothly.

Air flow through the Bleed Screw hole should be detectable while the log splitter is under operations.

Before moving the log splitter, make sure the Bleed Screw is tightened to avoid oil leaking from this point.

Failed to loosen the bleed screw will keep the sealed air in hydraulic system being compressed after being decompressed, such continuous air compression and decompression will blow out the seals of the hydraulic system and cause permanent damage to the log splitter.

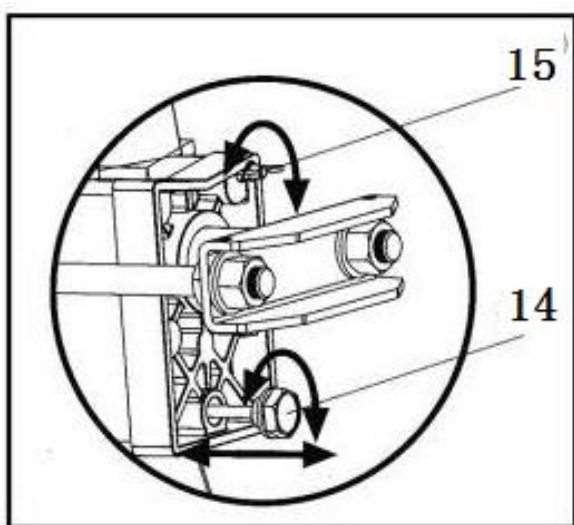

Fig.6

**DO NOT ADJUST THE MAX PRESSURE LIMITING SCREW (16) IN FIG. 7!**

Max pressure was set before the log splitter ex work and the max pressure limiting screw is tightened to ensure the log splitter works under pressure no more than 6 tons. The setting was done by qualified mechanic with professional instruments.

Unauthorized resetting will cause the hydraulic pump fail to output enough splitting pressure or **RESULT IN SERIOUS INJURY AS WELL AS DAMAGE TO THE MACHINE.**

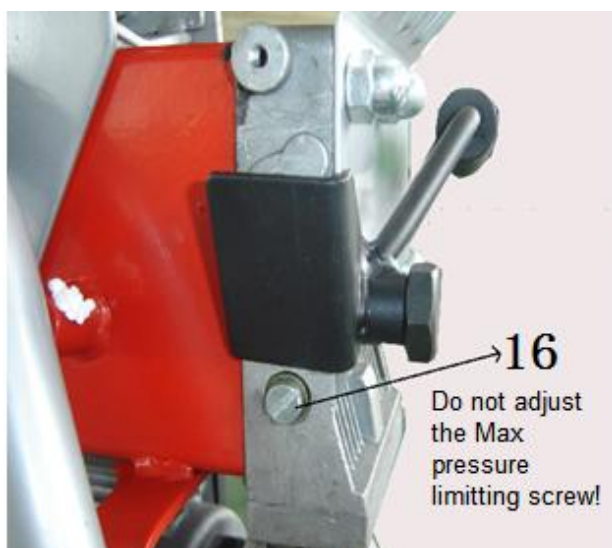
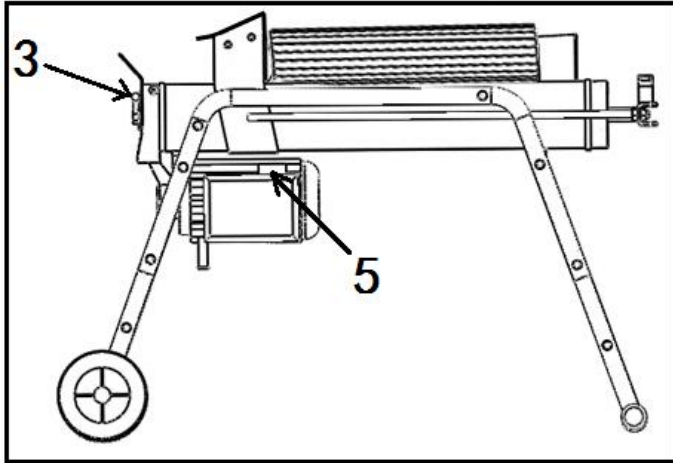

Fig. 7

**Make sure that the screws are tightened up properly before operation the log splitter!**

This log splitter is equipped with control system that requires to be operated by both hands of the user – left hand controls the hydraulic control lever (3) while right hand controls the push button switch (5) as shown in Fig. 8. The log splitter will freeze upon absence of either hand. Only after both hands release the controls, the log pusher starts to return backward to the starting position.

**Never force the log splitter for more than 5 seconds by keeping pressure on it to split excessively hard wood.**

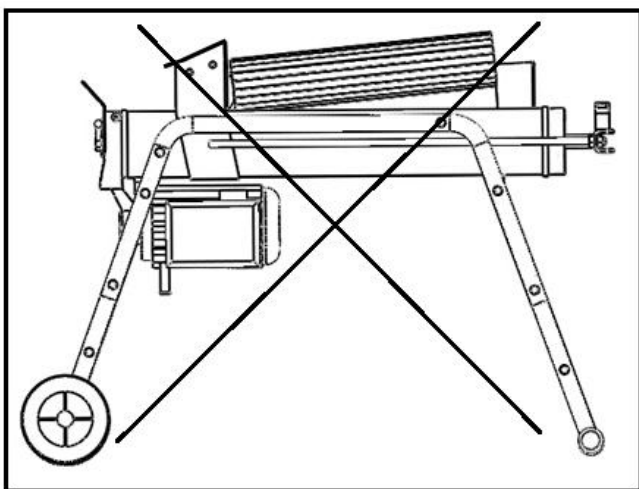

**Fig .8**

After this time interval, the oil under pressure will be overheated and the machine could be damaged. For such extremely hard log, rotate it by 90° to see whether it can be split in a different direction. In any case, if you are not able to split the log, this means that its hardness exceeds the capacity of the machine and thus that log should be discarded to protect the log splitter.

**NOTE:** During operation, the metal part connected to the motor remains cold or in any case reaches a temperature only slightly higher than the ambient temperature. After several hours of use with particularly difficult wood, the pump may become very hot. This is not a dangerous situation for the machine, which returns to full functioning capacity after being cooled. On the other hand, it is very important not to cause overheating of the oil, and thus the pump, by forcing the machine in an attempt to split logs that exceed the capacity of the machine.

**Always set logs firmly on the log retaining plates and work table. Make sure logs will not twist, rock or slip while being split. Do not force the blade by splitting the log on the upper part. This will break the blade or damage the machine. (Fig.9)**



**Fig. 9**

Break log in the direction of its grown grain. Do not place log across the log splitter for splitting. This may be dangerous and may seriously damage the machine.

Do not attempt to split 2 pieces of logs at the same time. One of them may fly up and hit you.

### Freeing a jammed log (fig.10)

1. Release both controls.
2. After the log pusher moves back and completely stops at its starting position, insert a wedge wood under the jammed log.
3. Start the log splitter to push the wedge wood to go completely under the jammed one.
4. Repeat above procedure with sharper slope wedge woods until the log is completely free.

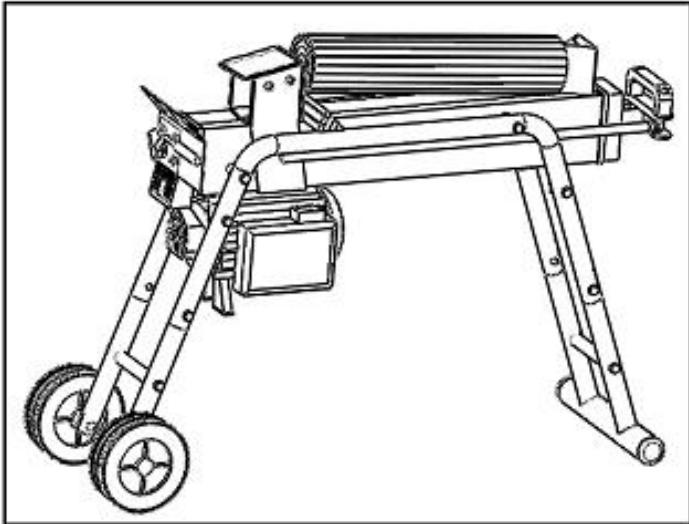

Fig.10

Do not try to knock the jammed log off. Knocking will damaged the machine or may launch the log and cause accident (fig.11).

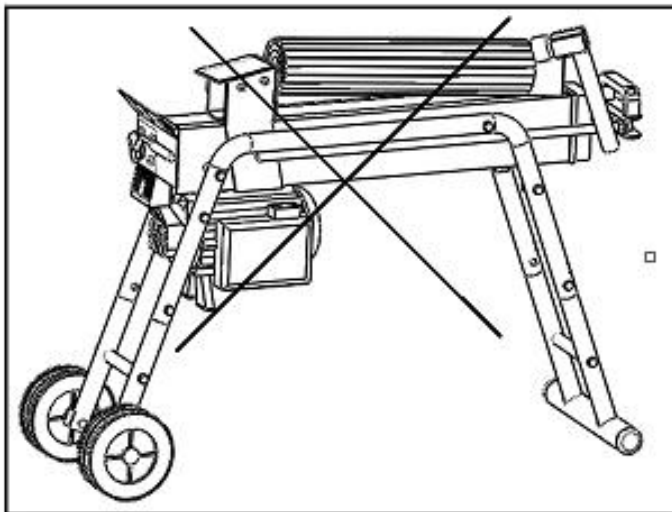

Fig.11

## 6. MAINTENANCE

### Replacing hydraulic oil (fig.12)

Replace the hydraulic oil in the log splitter after every 150 hours of use. Take following steps to replace it.

1. Make sure all moving parts stops and the log splitter is unplugged.
2. Unscrew oil drain bolt (14 ) (fig.6) with dipstick to remove it.
3. Turn the log splitter on the support leg side over a 2.4 liters capacity container to drain the hydraulic oil off.
4. Turn the log splitter on the motor side.
5. Refill fresh hydraulic oil at the volume as per the hydraulic oil capacity of a particular model indicated in the specifications table.
6. Clean the surface of Dipstick on the oil drain bolt and put it back into the oil tank while keep the log splitter vertically.
7. Make sure the level of the refilled oil is just between 2 grooves around the dipstick.
8. Clean the oil drain bolt before thread them back. Make sure they are tightened to avoid leakage before placing the log splitter horizontally.

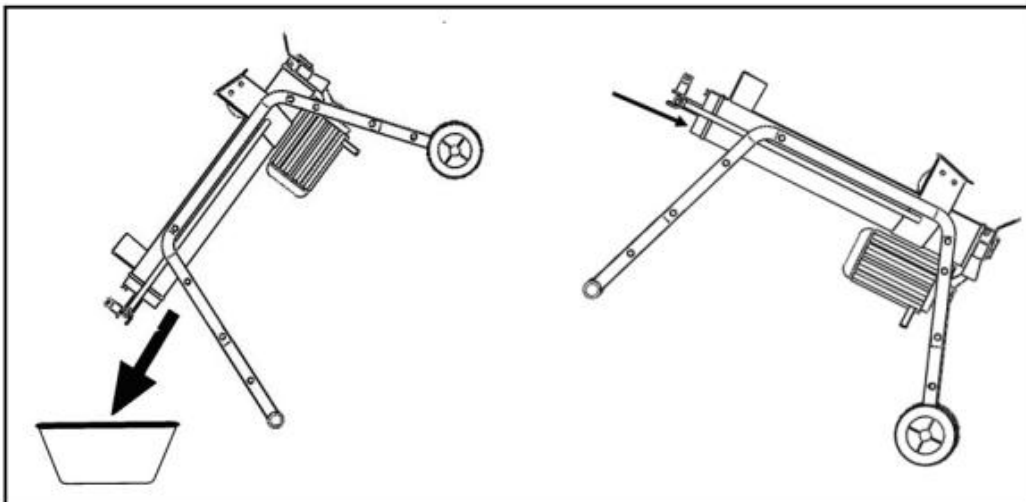

fig.12

Periodically check oil level to ensure it is between 2 grooves around the dipstick. Upon lower oil level, oil refilling is required.

**Warning: Never mix oil with general waste!**

**Used oil must be disposed of according to current regulations in the country where the machine is used.**

### Sharpening the wedge

After using the log splitter for some time, sharpen the wedge of the log splitter using a fine-toothed file and smooth any burrs or crushed area along the cutting edge

## 7. STORAGE

When you have finish working with your log splitter:

1. Disconnect the log splitter from the mains supply.
2. Tighten the oil yank cover / air bleeder,
3. Clean the unit down using a dry cloth.
4. Store in a dry and well-ventilated area.

## 8. TROUBLESHOOTING

PROBLEM	PROBABLE CAUSE	REMEDY SUGGESTED
Motor stops starting	Overload protection device disengaged to protect the log splitter from being damaged	Let motor cool down, and push the button of the overload protection device to re-start the motor
Fails to split logs	Log is improperly positioned	Refer to “Log splitter operation” section for perfect log loading
	The sizes or hardness of the log exceeds the capacity of the machine	Reduce the log size before splitting it on the log splitter
	Wedge cutting edge is blunt	Refer to “Sharpening wedge “section to sharpen the cutting edge.
	Oil leaks	Locate leak(s) and contact the dealer
	Unauthorized adjustment was made on Max. Pressure Limiting Screw. Lower max pressure rating was set.	Contact the dealer
The log pusher moves jerkily, taking unfamiliar noise or vibrating a lot	Lack of hydraulic oil and excessive air in the hydraulic system	Check oil level for possible oil refilling. Contact the dealer.
Oil leaks around cylinder ram or from other points	Air sealed in hydraulic system while operating	Loosen bleed screw by some rotations before operating the log splitter
	Bleed screw is not tightened before moving the log splitter	Tight the bleed screw up before moving the log splitter
	Oil drain bolt with dipstick is not tight.	Tighten the oil drain bolt with dipstick
	Hydraulic control valve assembly and/or seal(s) worn.	Contact the dealer

## 9. DISPOSAL



Electrical products should not be discarded with household products. According to the European Directive 2012/19/EU on waste electrical and electronic equipment and its implementation into national law, electrical products used must be collected separately and disposed of at collection points provided for this purpose. Talk with your local authorities or dealer for advice on recycling.



# 10. DECLARATION OF CONFORMITY



BUILDER SAS

ZI, 32, rue Aristide Bergès – 31270 Cugnaux - France  
Tel : +33 (0)5.34.502.502 Fax : +33 (0)5.34.502.503

Declare that this machine:  
ELECTRIC LOGSPLITTER  
*Model: FFBE7TS*

Serial number: 20230606059-20230606143

Is in conformity with the Directive 2006/42/EC and the regulations transposing it;

Also in conformity with the following Directives:  
RoHS Directive (EU)2015/863 amending 2011/65/EU  
EMC Directive 2014/30/UE

Also in conformity with the following standards:

EN609-1:2017  
EN60204-1:2018  
EN55014-1: 2017/A11:2020  
EN IEC55014-1: 2021  
EN55014-2: 1997/A2:2008  
EN IEC55014-2: 2021  
EN61000-3-2: 2014  
EN IEC61000-3-2: 2019/A1:2021  
EN61000-3-11: 2000  
EN IEC61000-3-11: 2019

Responsible of technical file: Olivier Patriarca

Cugnaux, le 18/05/2023

Philippe MARIE / PDG

# 11. WARRANTY



## WARRANTY

The manufacturer guarantees the product against defects in material and workmanship for a period of 2 years from the date of the original purchase. The warranty only applies if the product is for household use. The warranty does not cover breakdowns due to normal wear and tear.

The manufacturer agrees to replace parts identified as defective by the designated distributor. The manufacturer does not accept responsibility for the replacement of the machine, in whole or in part, and/or ensuing damage.

### The warranty does not cover breakdowns due to:

- insufficient maintenance.
- abnormal assembly, adjustment or operations of the product.
- parts subject to normal wear and tear.

### The warranty does not extend to:

- shipping and packaging costs.
- using the tool for a purpose other than that for which it was designed.
- the use and maintenance of the machine done in a manner not described in the user manual.

Due to our policy of continuous product improvement, we reserve the right to alter or change specifications without notice. Consequently, the product may be different from the information contained therein, but a modification will be undertaken without notice if it is recognized as an improvement of the preceding characteristic.

### READ THE MANUAL CAREFULLY BEFORE USING THE MACHINE.

When ordering spare parts, please indicate the part number or code, you can find this in the spare parts list in this manual. Keep the purchase receipt; without it, the warranty is invalid. To help you with your product, we invite you to contact us by phone or via our website:

- **+33 (0)9.70.75.30.30**
- **<https://services.swap-europe.com/contact>**

You must create a "ticket" via the web platform.

- Register or create your account.
- Indicate the reference of the tool.
- Choose the subject of your request.
- Describe your problem.
- Attach these files: invoice or sales receipt, photo of the identification plate (serial number), photo of the part you need (for example: pins on the transformer plug which are broken).



# 12. PRODUCT FAILURE

## WHAT TO DO IF MY MACHINE BREAKS DOWN?

### **If you bought your product in a store:**

- a) Empty the fuel tank if your product has one.
- b) Make sure that your machine is complete with all accessories supplied, and clean! If this is not the case, the repairer will refuse the machine.

Go to the store with the complete machine and with the receipt or invoice.

### **If you bought your product on a website:**

- a) Empty the fuel tank if your product has one.
- b) Make sure that your machine is complete with all accessories supplied, and clean! If this is not the case, the repairer will refuse the machine.
- c) Create a SWAP-Europe service ticket on the site: <https://services.swap-europe.com> When making the request on SWAP-Europe, you must attach the invoice and the photo of the nameplate (serial number).
- d) Contact the repair station to make sure it is available before dropping of the machine.

Go to the repair station with the complete machine packed, accompanied by the purchase invoice and the station support sheet downloadable after the service request is completed on the SWAP-Europe site

For machines with engine failure from manufacturers BRIGGS & STRATTON, HONDA and RATO, please refer to the following instructions.

Repairs will be done by approved engine manufacturers of these manufacturers, see their site:

- <http://www.briggsandstratton.com/eu/fr>
- <http://www.honda-engines-eu.com/fr/service-network-page;jsessionid=5EE8456CF39CD572AA2AEEDFD290CDAE>
- <https://www.rato-europe.com/it/service-network>

**Please keep your original packaging to allow for after-sales service returns or pack your machine with a similar cardboard box of the same dimensions.**

**For any question concerning our after-sales service you can make a request on our website <https://services.swap-europe.com>**

**Our hotline remains available at +33 (9) 70 75 30 30.**



# 13. WARRANTY EXCLUSIONS

## THE WARRANTY DOES NOT COVER:

- Start-up and setting up of the product.
- Damage resulting from normal wear and tear of the product.
- Damage resulting from improper use of the product.
- Damage resulting from assembly or start-up not in accordance with the user manual.
- Breakdowns related to carburetion beyond 90 days and fouling of carburetors.
- Periodic and standard maintenance events.
- Actions of modification and dismantling that directly void the warranty.
- Products whose original authentication marking (brand, serial number) has been degraded, altered or withdrawn.
- Replacement of consumables.
- The use of non-original parts.
- Breakage of parts following impacts or projections.
- Accessories breakdowns.
- Defects and their consequences linked to any external cause.
- Loss of components and loss due to insufficient screwing.
- Cutting components and any damage related to the loosening of parts.
- Overload or overheating.
- Poor power supply quality: faulty voltage, voltage error, etc.
- Damages resulting from the deprivation of enjoyment of the product during the time necessary for repairs and more generally the costs related to the immobilization of the product.
- The costs of a second opinion established by a third party following an estimate by a SWAP-Europe repair station
- The use of a product which would show a defect or a breakage which was not the subject of an immediate report and/or repair with the services of SWAP-Europe.
- Deterioration linked to transport and storage\*.
- Launchers beyond 90 days.
- Oil, petrol, grease.
- Damages related to the use of non-compliant fuels or lubricants.

\* In accordance with transport legislation, damage related to transport must be declared to carriers within 48 hours maximum after observation by registered letter with acknowledgement of receipt.

This document is a supplement to your notice, a non-exhaustive list.

**Attention:** all orders must be checked in the presence of the delivery person. In case of refusal by the delivery person, it you must simply refuse the delivery and notify your refusal.

**Reminder:** the reserves do not exclude the notification by registered letter with acknowledgement within 72 hours.

### Information:

Thermal devices must be wintered each season (service available on the SWAP-Europe site). Batteries must be charged before being stored.

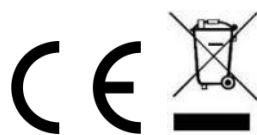

BUILDER SAS

32 rue Aristide Bergès - Z.I. du Casque - 31270 Cugnaux - France

Made in PRC